

E26_{BSR} **E29_{BSR}** **E35_{BSR}**
E39_{BSR} **E45_{BSR}** **E50_{BSR}**



	E26BSR	E29BSR	E35BSR	E39BSR	E45BSR	E50BSR
OPERATING WEIGHT	2.70 t	2.84 t	3.50 t	3.90 t	4.54 t	4.95 t
DIGGING DEPTH	2.650 mm	2.790 mm	3.100 mm	3.350 mm	3.660 mm	3.900 mm

Data refers to cab versions with long arm



BUILT AROUND YOU

ULTRA COMPACT HEAVY EXCAVATO

**OUTSTANDING
PERFORMANCE**

**ULTRA SHORT RADIUS
OPTIMISES
YOUR WORK**

**COMFORTABLE
WORK
ENVIRONMENT**



RS TECHNOLOGY

**EASY TO
TRANSPORT**

BUILT TO LAST

**EASY DAILY
MAINTENANCE**



OUTSTANDING PERFORMANCE



EXCELLENT FRONT- AND SIDE-DIGGING PERFORMANCE

New generation engines

Our engines comply with Tier IV regulations and grant a superior digging capacity with low fuel consumption and noise level.

High oil flow

The high oil flow has many benefits: it allows the use of larger cylinders that result in superior breakout forces, it allows digging with larger buckets and it reduces loading cycle time.

Boom Offset Function

This function allows parallel digging without moving the undercarriage, resulting in precise and safe ditch and pipe laying operations

DIGGING DEPTH

E26B	2.7 m
E29B	2.8 m
E35B	3.1 m
E39B	3.4 m
E45B	3.7 m
E50B	3.9 m

BETTER DIGGING PERFORMANCE WITH THE SAME HYDRAULIC SYSTEM OF A LARGE EXCAVATOR

Enjoy the high productivity of New Holland Kobelco heavy excavator's Smart Hydraulic System with Japanese technology in your mini excavator!

The Smart Hydraulic System relies on three integrated pumps to deliver accurate dozer operation and total simultaneous movements. The third pump powers the blade and swing circuits independently from travel. When digging, the flow from this pump is redirected to the arm to deliver added power and ensure smooth operation under heavy loads.



HIGH LIFTING CAPACITY

Front and side lifting capacity at 2 meters from swing center.

Lifting capacity in tonnes

DEPTH LEVEL	E26B		E29B		E35B		E39B		E45B		E50B		E50B**	
	2.0 m		2.0 m		2.0 m		2.0 m		2.0 m		2.0 m		2.0 m	
	FRONT	SIDE	FRONT	SIDE	FRONT	SIDE	FRONT	SIDE	FRONT	SIDE	FRONT	SIDE	FRONT	SIDE
Ground	0.9	0.6	1.1	0.8	1.1	0.9	1.4	1.3	1.4	1.4	1.7	1.7	1.6	1.6
1 m below ground	1.0	0.7	1.1	0.8	1.1	0.9	1.6	1.3	2.1	1.6	2.8	1.9	2.8	1.8
2 m below ground	0.7*	0.7*	0.7	0.7	1.1	0.9	1.5	1.4	2.1	1.7	2.9	2.0	2.8	1.9

* 1,5m below ground / ** Long Arm

POWERFUL AND EFFICIENT DOZER PERFORMANCE

Unique Dozer-Blade Shape

New Holland's unique dozer blade design moves it into an arc, so that earth falls forward. This prevents the earth from falling behind the blade, leaving a clean surface in one pass.

MORE PUSHING POWER

Great Grip

The front crawler idlers have been adjusted to increase the area of contact between the crawler shoes and the ground. The 5 lower track rollers plus the upper track roller perfectly guide the tracks minimizing the risk of de-tracking. This also reduces noise and vibrations when travelling.



ULTRA SHORT RADIUS



FAST LOADING CYCLES

The Ultra Short Radius concept means that the machine tail always stands in the crawler width. The advantages of this design are:

- Possibility to work in very limited spaces
- No risk of damaging the rear of the machine when swinging
- Better integration in urban jobsites
- Possibility to work closer to the truck and therefore dumping further

The Short Radius tail combined with the superior digging depth plus an efficient hydraulic system that allows a full upper frame rotation in less than 7 seconds, result in extremely short loading cycle times

SAFETY AND PRODUCTIVITY IN LIMITED SPACES

With the Short Radius design the operator doesn't have to worry about the rear of the machine when swinging. He can concentrate instead on the job in front of him, which increases performance efficiency and safety.

The zero tail radius combined with the side-ditch digging function (Boom Offset Function) makes it easy to dig next to walls with a compact operating footprint that makes digging, swinging and dumping possible in very limited spaces.

SAFE OBJECT HANDLING KIT

For your safety on the jobsite, New Holland introduced the optional Object Handling Kit, which includes lifting hook safety valves on the boom, and a dipper overload device with alarm inside the cab.

New Holland certifies that this kit complies with EN 474-5 regulation.
This kit is available on E26B SR and bigger models.



Lifting hook



Safety valves included in the Safe Handling option.

WELCOME ON BOARD



GREAT COMFORT FOR TOUGH JOBS!

- Ergonomic and accurate joysticks grant more effective working days and less fatigue
- Excellent seat comfort thanks to suspended seat with adjustable arm rest, high back support and headrest
- Limited heating from the hydraulic distributor due to its convenient location on right side of the machine, under the hood
- Optimized natural ventilation with sliding side windows and removable lower front windows
- Cab temperature under control with standard heating and optional air conditioning, even during warm summer days
- Monitor display with easy-to-read angle
- Convenient tool kit behind the seat
- Smart cup holder
- Easy to read hour-meter
- Convenient 12V plug to recharge cell phones or other devices.



OUTSTANDING VISIBILITY MEANS SAFE OPERATIONS

- All round visibility provides safety and makes you feel more confident
- Great visibility also during loading and dumping operations thanks to transparent roof
- Reinforced cab and canopy structure: all models are ROPS / FOPS and TOPS certified
- Smooth and accurate control of machine at work.



PROGRESSIVE CONTROL

- E35B SR and bigger models are equipped with standard proportional controls. This allows smooth and progressive attachment handling operations.

EASY CAB ACCESS

- Wide opening door with smart and reliable opening system
- The curved shape of the door allows its opening in confined spaces
- Left-hand joystick support with safety lever that rises very high
- On canopy versions it is the 3 pillar design that grants excellent accessibility

EASY TRANSPORT BETWEEN JOBS



EASY LOADING

The higher approach angle (up to 38°) allows high lifting of the dozer blade. This makes it easy to load the machine onto a truck.

ON A TRAILER WITHOUT SPECIFIC DRIVING LICENSE

E26B cab or E29B canopy:

Transport weight _____ 2.592 kg

300 mm bucket _____ 37 kg

450 mm bucket _____ 44 kg

1200 mm bucket _____ 54 kg

Quick coupler _____ 24 kg

Machine + attachments _____ 2751 kg

E26B cab or E29B canopy together with 3 NH buckets equipped with quick coupler can be transported on a trailer, whose weight does not exceed 749 kg.





HOW WIDE IS YOUR TRUCK TRAILER?

MODEL HEIGHT

E26B	2.46 m
E29B	2.50 m
E35B	2.57 m
E39B	2.57 m
E45B	2.60 m
E50B	2.60 m

MODEL WIDTH

E26B	1.40 m
E29B	1.50 m
E35B	1.55 m
E39B	1.70 m
E45B	1.96 m
E50B	1.96 m

LIFTING POINTS MAKE THE LOADING OF THE MACHINE EASIER

New Holland Mini excavators can easily be lifted by hooking steel cables at both dozer ends (A) and at the indicated point on the boom (B).

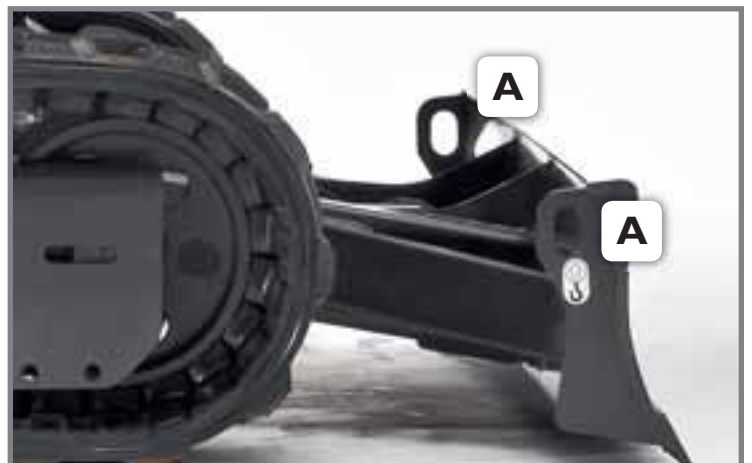

Detailed lifting procedures of complete machine are indicated in the Operator's Manual.

BUILT TO LAST

HIGHLY RELIABLE DESIGN

Highly reliable design and attention to details provide a high level of performance also in the long term.

Boom, arm and swing bracket are made of large cross-section reinforced steel. This gives grants longevity and durability to the machine.

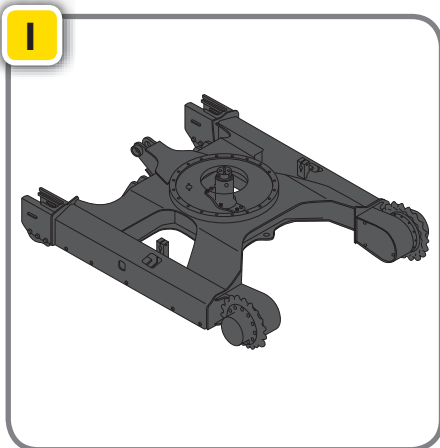

1 make New Holland mini excavators robust and stable



2 Protected hose connections = long life



3 Boom cylinder is protected in every working condition



4



Molded boom swing articulation + No exposed hoses = long life

5



High quality steel piping

6



Reinforced boom/arm connection

EASY MAINTENANCE

EASY DAILY MAINTENANCE

EASY GROUND LEVEL SERVICING

When it's time to perform routine maintenance, New Holland makes it easy with the extra-wide engine and hydraulic system door opening and with ground level access to key components such as:

- Filters
- Radiators
- Auxiliary circuit selector
- Fuel tank

EXCLUSIVE SUPER FINE FILTER

This exclusive super-fine filter is environmentally friendly, lasts 1000 hours and is easy to replace.

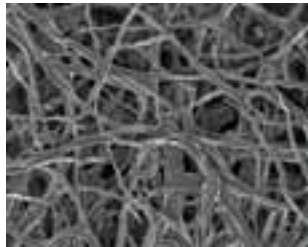

Conventional filter

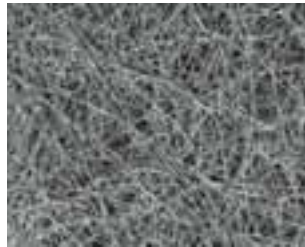

Super fine filter



Radiators are easy to clean.



Fuel tank can be easily filled from the ground.



Easy and quick access to the selector of auxiliary circuit: mono- or bi-directional.





THE ATTACHMENTS

DESIGNED FOR ATTACHMENTS

New Holland excavators were designed to allow easy attachment handling. Our Tier IV compact excavators include auxiliary hydraulics as standard equipment. That makes them factory-ready for grapples, breakers and many other attachments.

All attachments have been designed, tested and approved by New Holland Engineering respecting machines' kinematics and ensuring the maximum productivity and safety.

QUICK COUPLER

You can easily change your attachments whenever you need thanks to « Klac » self locking system. Its compact design respects original kinematic and doesn't need any maintenance operation. This grants the best productivity of your machine.

BUCKETS

- Excavation or heavy duty buckets: from 250 mm / 35 L to 900 mm / 210 l
- Ditch cleaning buckets: from 1.000 mm / 102 l to 1.500 mm / 260 l

Your existing buckets can easily be adapted to the Klac system with the Klac Adapter kit. Klac Reverse quick coupler is also available.

AUGERS

Designed specifically for any application requiring the boring of holes

- **Standard duty drive (chain drive)** Hydraulic flow : min 23 lpm / max 57 lpm
 - **Heavy duty drive (planetary drive)** Hydraulic flow : min 30 lpm / max 57 lpm
- Auger diameters from 100 mm to 900 mm / length 1220 mm
Auger extensions : from 300 to 1830 mm

CUTTER CRUSHER C60

C60 is a robust and durable cutter crusher with one moving jaw that can be mechanically rotated 360°. Its closed structure and Hardox steel jaws make it a solid durable tool suitable for steel.

WEIGHT (kg)	CRUSHING FORCE REAR (kN)	MAX. CUTTING FORCE (kN)
205	180	460

SORTING & DEMOLITION GRAB D03HPX-40

Different applications possible through easy exchange system of the shells.

The hydraulic cylinder is replaced by the maintenance free "HPX Drive" : more compact and resistant against dirt and blows.

Extending service life up to 50%: the drive unit runs in a permanent oil bath, no lubrication is required. Long life is ensured due to the use of 500 HB steel in the manufacture of side plates and cutting edges.

WEIGHT (kg)	VOLUME (l)	TORQUE (Nm)	CLOSING FORCE (kN)	LOAD CAPACITY (kg)
260	60	1.000	26	1.000



HAMMERS

New Holland Hammers are highly performing and durable. Their limited dimensions help you to work in narrow spaces.

	TOOL DIAMETER (mm)	IMPACT FREQUENCY (BPM)	WEIGHT (kg)	SOUND LEVEL (dBA)	E26B E29B	E35B E39B	E45B	E50B
CB27S (silenced)	42 mm	1.600-2.600 BPM	120 kg	123 dBA	x			
CB32	45 mm	750-2.400 BPM	130 kg	129 dBA	x	x		
CB32S (silenced)	45 mm	750-2.400 BPM	140 kg	123 dBA	x	x		
CB37S (silenced)	50 mm	1.800-2.000 BPM	175 kg	124 dBA		x		
CB45	50 mm	450-1.800 BPM	200 kg	128 dBA		x	x	x
CB45S (silenced)	50 mm	450-1.800 BPM	220 kg	118 dBA		x	x	x
CB65	63 mm	400-2.000 BPM	300 kg	132 dBA			x	x
CB65S (silenced)	63 mm	400-2.000 BPM	315 kg	121 dBA			x	x
CB90S (silenced)	80 mm	500-1.700 BPM	360 kg	127 dBA				x

This hammers can be fitted directly on the machine or with an adapter plate on a Klac or Lehnhoff quick coupler.

SPECIFICATIONS & DIMENSIONS

E26BSR - E29BSR

MODEL CODE

Cab.....NK26MC - NK29MC
Canopy.....NK26MR - NK29MR

ENGINE

Displacement.....1.331 cm³
Power.....23 hp
Max torque.....80.1 Nm
Emissions level.....Tier IV

HYDRAULIC SYSTEM

Variable displacement pumps type.....axial piston
Flow delivery.....2 x 26.4 l/min
Gear pump delivery.....14.3 l/min
Maximum operating pressure.....230 bar

SLEWING AND TRAVEL SPEED

Slewing speed.....8.7/8.8 rpm
Boom slewing angle (left/right).....60° / 55°
Travel Speed - Low (1st).....2.3 km/h
Travel Speed - High (2nd).....4.1 km/h

E35BSR - E39BSR

MODEL CODE

Cab.....NK35MC - NK39MC
Canopy.....NK35MR - NK39MR

ENGINE

Displacement.....1.642 cm³
Power.....30 hp
Max torque.....98.4 Nm
Emissions level.....Tier IV Interim

HYDRAULIC SYSTEM

Variable displacement pumps type.....axial piston
Flow delivery.....2 x 38.4 l/min
Gear pump delivery.....20.6 l/min
Maximum operating pressure.....230 bar

SLEWING AND TRAVEL SPEED

Slewing speed.....8.9 rpm
Boom slewing angle (left/right).....70° / 60°
Travel Speed - Low (1st).....2.5 km/h
Travel Speed - High (2nd).....4.5 km/h

E45BSR

MODEL CODE

Cab.....NK45MC
Canopy.....N.A.

ENGINE

Displacement.....2.189 cm³
Power.....43 hp
Max torque.....139.3 Nm
Emissions level.....Tier IV Interim

HYDRAULIC SYSTEM

Variable displacement pumps type.....axial piston
Flow delivery.....2 x 57.1 l/min
Gear pump delivery.....33.8 l/min
Maximum operating pressure.....230 bar

SLEWING AND TRAVEL SPEED

Slewing speed.....8.8 rpm
Boom slewing angle (left/right).....70° / 60°
Travel Speed - Low (1st).....2.8 km/h
Travel Speed - High (2nd).....4.6 km/h

E50BSR

MODEL CODE

Cab.....NK50MC
Canopy.....N.A.

ENGINE

Displacement.....2.189 cm³
Power.....43 hp
Max torque.....139.3 Nm
Emissions level.....Tier IV Interim

HYDRAULIC SYSTEM

Variable displacement pumps type.....axial piston
Flow delivery.....2 x 57.1 l/min
Gear pump delivery.....33.8 l/min
Maximum operating pressure.....230 bar

SLEWING AND TRAVEL SPEED

Slewing speed.....8.8 rpm
Boom slewing angle (left/right).....70° / 60°
Travel Speed - Low (1st).....2.8 km/h
Travel Speed - High (2nd).....4.6 km/h

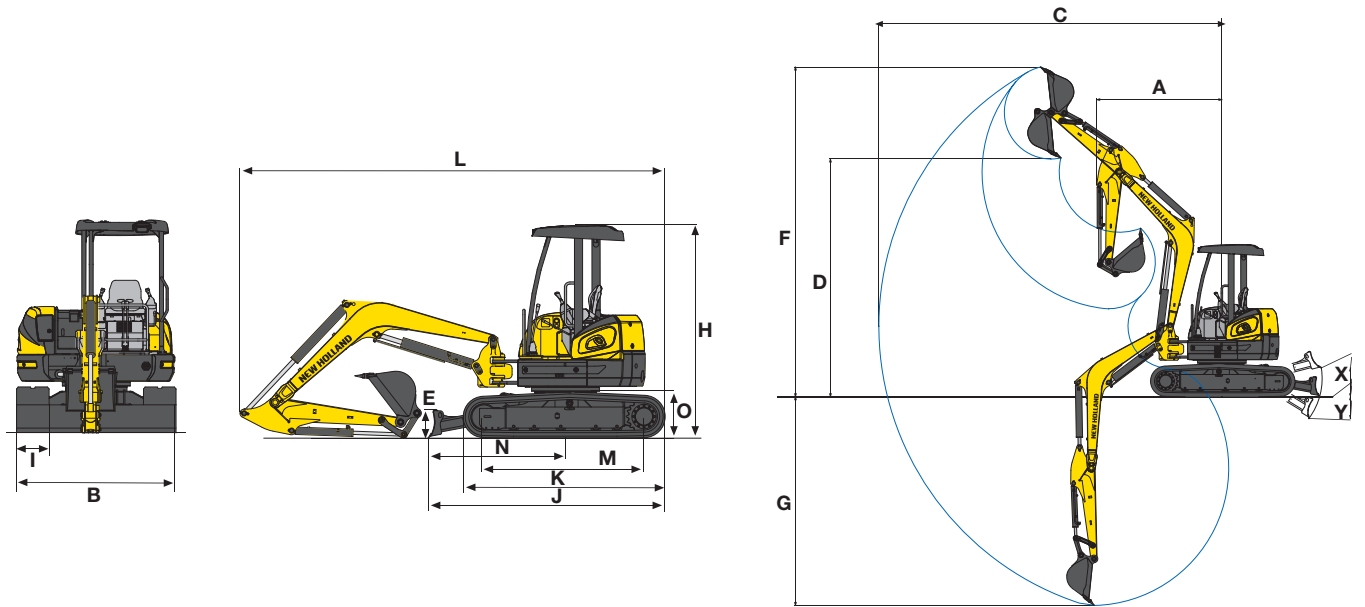

		E26BSR	E29BSR	E35BSR	E39BSR	E45BSR	E50BSR	
Rear end swing radius	mm	700 / 740 *	750	775	850	980	980	980
I - Track width	mm	250	250	300	300	400	400	400
J - Undercarriage length	mm	2.260	2.410	2.550	2.680	2.780	2.910	2.910
K - Track length on ground	mm	1.870	1.980	2.000	2.150	2.330	2.480	2.480
M - Center distance of tumblers	mm	1.490	1.590	1.540	1.700	1.820	1.970	1.970
N - Blade radius on ground	mm	1.350	1.440	1.550	1.600	1.621	1.690	1.690
X - Blade max lifting	mm	425	445	560	540	505	495	495
Y - Blade max lowering	mm	290	335	410	440	325	375	375
B - Blade width	mm	1.400	1.500	1.550	1.700	1.960	1.960	1.960
E - Blade height	mm	300	300	345	345	345	345	345

* Canopy 700 mm / Cab 740 mm

DIGGING PERFORMANCE

		E26BSR	E29BSR	E35BSR	E39BSR	E45BSR	E50BSR	
Dipperstick	mm	1.330	1.370	1.470	1.590	1.700	1.560	1.870
Bucket thickness	mm	450	600	500	600	650	700	700
G - Max digging depth	mm	2.650	2.790	3.100	3.350	3.660	3.590	3.900
Bucket Breakout force	kN	19,3	22,0	27,4	27,4	35,3	35,3	35,3
Dipperstick Breakout force	kN	12,0	13,0	15,0	17,0	20,0	26,3	23,6
A - Min front slew radius (Cab/Canopy)	mm	2.070/1.900	2.080/1.880	2.280/2.000	2.340/2.070	2.430	2.560	2.580
C - Max reach	mm	4.520	4.890	5.200	5.500	5.920	5.890	6.190
D - Max dump height (Cab/Canopy)	mm	2.650/2.950	3.170/3.380	3.200/3.550	3.430/3.760	3.790	3.680	3.840
F - Max digging height (Cab/Canopy)	mm	3.850/4.190	4.470/4.690	4.580/4.960	4.800/5.160	5.340	5.210	5.380

TRANSPORT FEATURE (weight is with full fuel tank, without operator, without bucket)

		E26BSR	E29BSR	E35BSR	E39BSR	E45BSR	E50BSR	
Weight (Cab)	tonnes	2,59	2,73	3,34	3,74	4,35	4,73	4,76
Weight (Canopy)	tonnes	2,27	2,59	3,20	3,60	N.A.	N.A.	N.A.
B - Max width	mm	1.400	1.500	1.550	1.700	1.960	1.960	1.960
L - Max length	mm	3.820	4.130	4.390	4.710	5.000	5.230	5.370
H - Max height	mm	2.460	2.500	2.570	2.570	2.600	2.600	2.600

OPERATING WEIGHT (includes operator, full fuel tank and one bucket)

		E26BSR	E29BSR	E35BSR	E39BSR	E45BSR	E50BSR	
Dipper	type	Standard	Standard	Standard	Standard	Standard	Short	Long
Cab	tonnes	2,70	2,84	3,50	3,90	4,54	4,92	4,95
Canopy	tonnes	2,38	2,70	3,36	3,76	N.A.	N.A.	N.A.

PARTS AND SERVICE

The New Holland dealer network is, in itself, the best guarantee of continued productivity for the machines it delivers to its customers. New Holland service technicians are fully equipped to resolve all maintenance and repair issues, with each and every service point providing the high standards they are obliged to observe under New Holland's stringent quality guidelines. The New Holland global parts network ensures fast, reliable, replacement parts for less downtime, increased productivity and, of course, profitable operation for its customers.



AT YOUR OWN DEALERSHIP

The information contained in this brochure is intended to be of general nature only. The NEW HOLLAND KOBELCO CONSTRUCTION MACHINERY S.p.A. company may at any time and from time to time, for technical or other necessary reasons, modify any of the details or specifications of the product described in this brochure. Illustrations do not necessarily show products in standard conditions. The dimensions, weights and capacities shown herein, as well as any conversion data used, are approximate only and are subject to variations within normal manufacturing techniques.

Published by NEW HOLLAND KOBELCO CONSTRUCTION MACHINERY S.p.A.
Printed in Italy - MediaCross Firenze - Cod 30635GB - Printed 01/13

Printed on recycled paper
CoC-FSC 000010 CQ Mixed sources



ELEMENTAL
CHLORINE
FREE
GUARANTEED



www.newholland.com

